

contacting the Codes Office for a field inspection previous to installation of the finish product.

Building Lot and Impervious Cover Information for Driveway Applications:

Total Lot Area: _____ Sq. Ft.
Existing Structure Area: _____ Sq. Ft.
Total Building Area: _____ Sq. Ft.
Total Existing Building Coverage (dwelling, decks, car ports, sheds, garages): _____ Sq. Ft.
Total Existing Impervious Cover (above plus walkways, driveways, patios): _____ Sq. Ft.

If the property is on a corner, it must have ramped entrances to comply with the ADA Act including truncated dome/detectable warning pads. Please see additional specification requirements attached to this application.

On August 9, 2011, Phoenixville Borough Council adopted the "Neighborhood Blight Protections and Enforcement" Ordinance 2180, that enables Borough Staff to deny any permit application if the owner of said property, on that or any other property owned in the Commonwealth, (1) has Tax and/or Municipal Services delinquencies on account of the actions of the Owner; or (2) has a Serious Violation with having no corrective, Substantial Steps in place. A printed copy of this ordinance is available upon request at the Borough Code Enforcement Department.

Borough of Phoenixville Code Chapter 27, Part 602.1.E.3: Performing any construction operation or operating or permitting the operation of any tools or equipment used in construction, drilling or demolition work between the hours of 6:00 p.m. and 8:00 a.m. or at any time on weekends, if such operation creates a noise disturbance across a real property boundary line or within a noise-sensitive zone. This section does not apply to domestic power tools or vehicles which are designed for transportation use on public highways.

I hereby certify that the proposed work is authorized by the owner of record and that I have been authorized by the owner to make this application as the authorized agent and we agree to conform to all applicable laws of this jurisdiction. Construction shall comply with all Borough Codes and the most current ICC Building Codes as adopted by the Commonwealth of Pennsylvania. Building/Structure shall also comply with the American Disabilities Act of 1990 where applicable. I have examined this application, its requirements and to my knowledge and belief, is a true, correct and complete application.

Applicant's Signature: _____ Date: _____

I would like: To be called to pick up the permit upon approval To have the permit mailed

Please be advised: As per the Borough of Phoenixville Schedule of Fees, the applicant shall be responsible for any additional Consultant Fees above and beyond the collected inspection fees on an "as invoiced" basis that may not be able to be ascertained at the submission of the application, and are due upon pick up.

OFFICE USE ONLY

Submitted Documents:

Plot Plan	YES	NO	N/A
Building Plans (sealed/signed)	YES	NO	N/A
Specifications	YES	NO	N/A
Zoning Approval	YES	NO	N/A
Application Completion:	YES	NO	
Signature of Applicant:	YES	NO	

Accepted/Returned by: _____ Date: _____

Ordinance 2180 Clearance: _____ Date: _____

Building Code Official: _____ Date: _____

Zoning Officer: _____ Date: _____

Driveway and Sidewalk Construction Standards

§25-203 (1) Prohibited Acts

No person, firm or corporation shall remove, destroy, break, cut, prune, trim, scrape, paint, whitewash or in any way deface, injure or interfere with the roots, trunk, bark, branches, leaves, flowers or fruit of any public shade trees in the Borough of Phoenixville without the permission of the Borough Manager for the work to be done. **Compliance with this part shall be confirmed by contacting the Codes Office for a field inspection previous to installation of the finish product.**

§21-1101 Driveway Construction

Driveways shall be constructed either of concrete or bituminous concrete, including that portion between the sidewalk and the street, the same to be installed consistent with good construction practices as defined by the Borough Manager in a writing made part of the Borough Records.

§21-307 Material and Specifications for Sidewalks

- 1) All sidewalks hereafter constructed, reconstructed or repaired in the Borough shall be made of concrete, according to specifications adopted by the Borough from time to time, such specifications to meet a maximum 3,000 pound compression test in 28 days.
- 2) All sidewalks shall be broom finished.
- 3) When there is danger of freezing, 2% of calcium chloride shall be added to the batch and the finished work shall be covered with salt hay.
- 4) All concrete shall be placed in a single course and finished without the addition of top mortar.
- 5) Sidewalks shall be laid to the line and grade obtained in advance from the Borough Manager, with a slope of 1/4 inch to the foot to the top of the curb.
- 6) Sidewalks shall be constructed with every block scored at six-foot intervals, with expansion strips every 30 feet.
- 7) The subgrade shall be firm and thoroughly tamped or rolled, and if so required by the Borough Manager, cinders or similar material shall be used before any concrete is placed.
- 8) In case of any sidewalk heretofore lawfully constructed of material other than concrete, such sidewalk may be repaired of the same material of which it was originally constructed, but if such sidewalk shall, at any time, be in such state of disrepair that, in the judgment of the Borough Manager, reconstruction, rather than repair, is necessary, such sidewalk shall be reconstructed of concrete and shall conform in all respect to the requirements of this Part applicable to new sidewalks.
- 9) Excepted from the above shall be sidewalks that are part of public works projects, which sidewalks may be constructed of materials other than concrete.

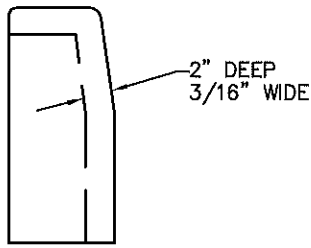

DETAIL "A"
CONTRACTION JOINT

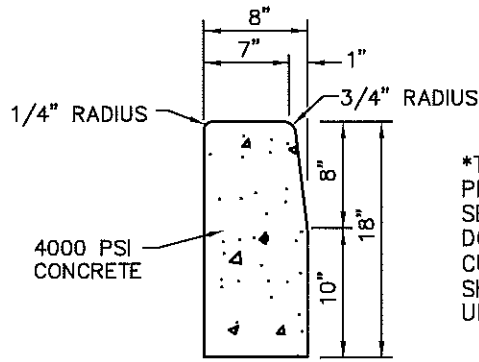

TYPICAL
CROSS SECTION

*THIS DETAIL IS THE STANDARD PENNDOT CONCRETE CURB CROSS SECTION. THE DIMENSIONS SHOWN DO NOT REFLECT THE DESIRED CURB REVEAL. ALL CURB SHALL HAVE A 6" CURB REVEAL UNLESS OTHERWISE DIRECTED.

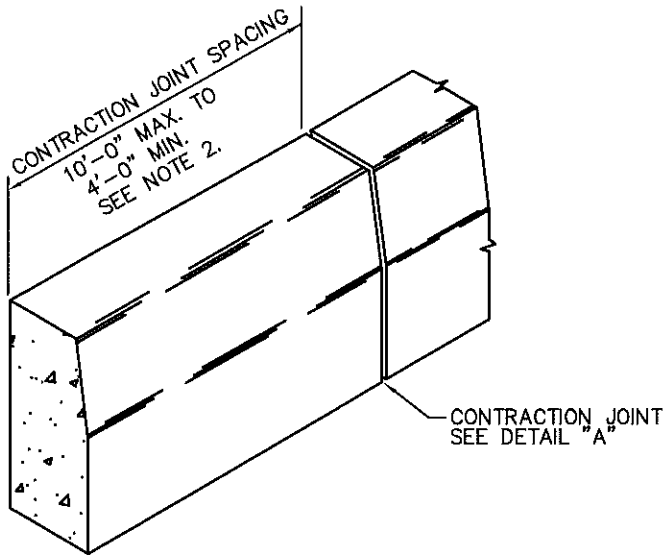

NOTES

1. PROVIDE MATERIALS AND CONSTRUCTION MEETING THE REQUIREMENTS OF PUBLICATION 408/2000, SECTION 630 FOR PLAIN CEMENT CONCRETE CURB AND DEPRESSED CURB, SECTION 640 FOR PLAIN CEMENT CONCRETE GUTTER AND SECTION 641 FOR PLAIN CEMENT CONCRETE CURB GUTTER.
2. SPACE CONTRACTION JOINTS IN UNIFORM LENGTHS OR SECTIONS.
3. PLACE 3/4" PREMOLDED EXPANSION JOINT FILLER MATERIAL AT STRUCTURES AND AT THE END OF THE WORK DAY. CUT MATERIAL TO CONFORM TO AREA ADJACENT TO CURB OR TO CONFORM TO CROSS SECTIONAL AREA OF CURB.
4. SEE RC-50M FOR PLAIN CEMENT CONCRETE CURB SLOPED TOP TREATMENT AT END OF STRUCTURES.
5. ALL CONCRETE IS TO BE 3,500 P.S.I., CLASS AA.
6. DEPRESSED CURB SHALL BE SLOPED 1/4" PER FOOT TOWARDS THE STREET.
7. CURB REPLACEMENT SHALL EXTEND TO THE NEAREST JOINT. SHOULD THE NEAREST JOINT EXTEND ACROSS A PROPERTY THE CURB MAY BE SAWCUT AT A LOCATION TO BE AND MARKED OUT BY THE BOROUGH.
8. CONTRACTOR SHALL PROVIDE EROSION CONTROLS TO CONTAIN OPEN EXCAVATIONS AND PROTECT THE NEAREST DOWNSTREAM INLET.

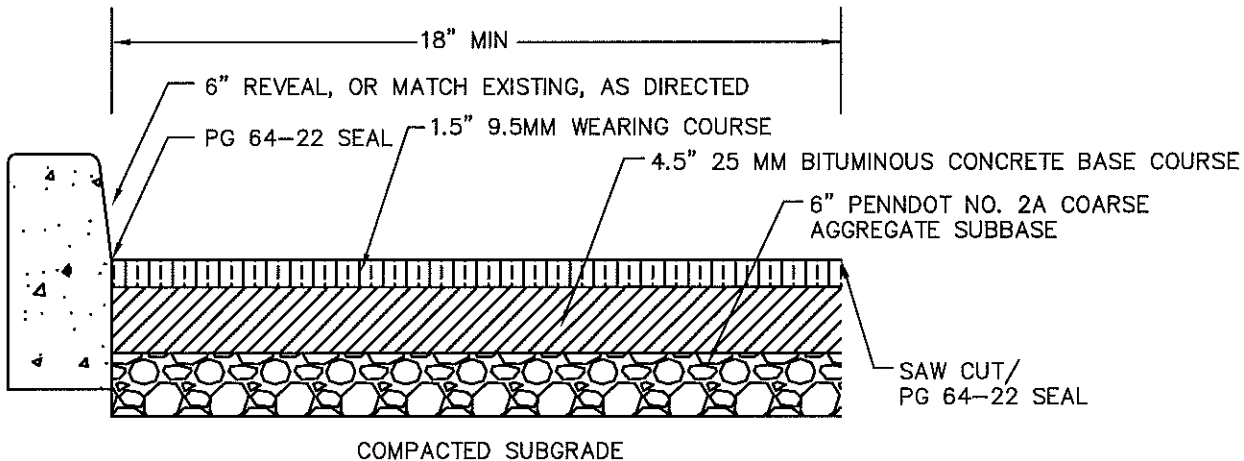

NOTES

1. ROADWAY RESTORATIONS SHALL BE PERFORMED ALONG STRAIGHT SAWCUT.
2. FAILURES IN THE EXISTING PAVEMENT MAY REQUIRE ANOTHER SAWCUT BE MADE IN ORDER TO INCORPORATE THE IRREGULARITIES INTO THE RESTORATION AREA.

DETAIL - G

CONSTRUCTION DETAILS
BOROUGH OF PHOENIXVILLE
CHESTER COUNTY, PENNSYLVANIA

GUTTER AND ROADWAY RESTORATION DETAIL

N.T.S.

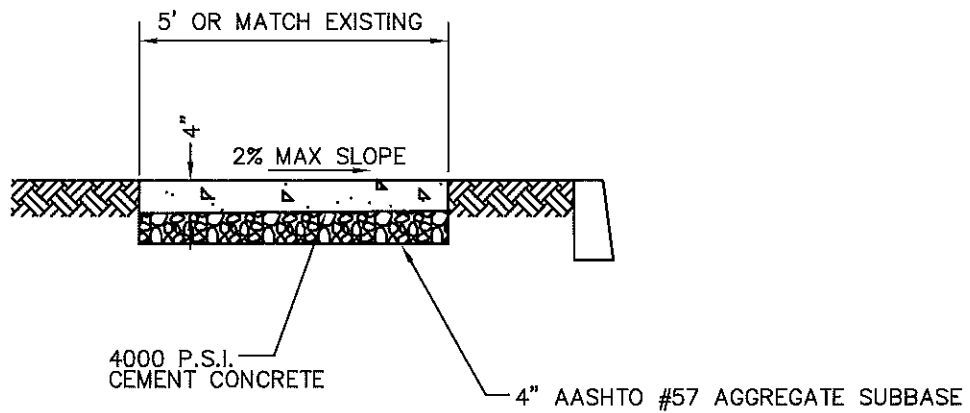
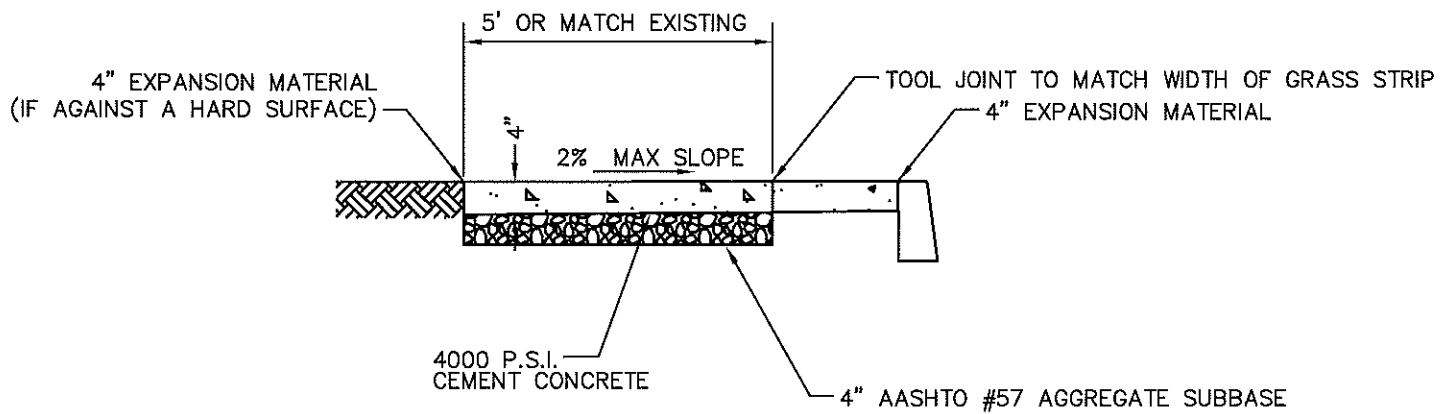

CEMENT CONCRETE SIDEWALK

N.T.S.

NOTE:

1. ALL CONCRETE IS TO BE 3,500 P.S.I., CLASS AA.
2. CONCRETE SIDEWALK SHALL BE SLOPED A MAXIMUM OF 2% TOWARDS THE TOP OF CURB.
3. CONTRACTOR SHALL PROVIDE EROSION CONTROLS TO CONTAIN OPEN EXCAVATIONS AND PROTECT THE NEAREST DOWNSTREAM INLET.

DETAIL - G
CONSTRUCTION DETAILS
BOROUGH OF PHOENIXVILLE
CHESTER COUNTY, PENNSYLVANIA

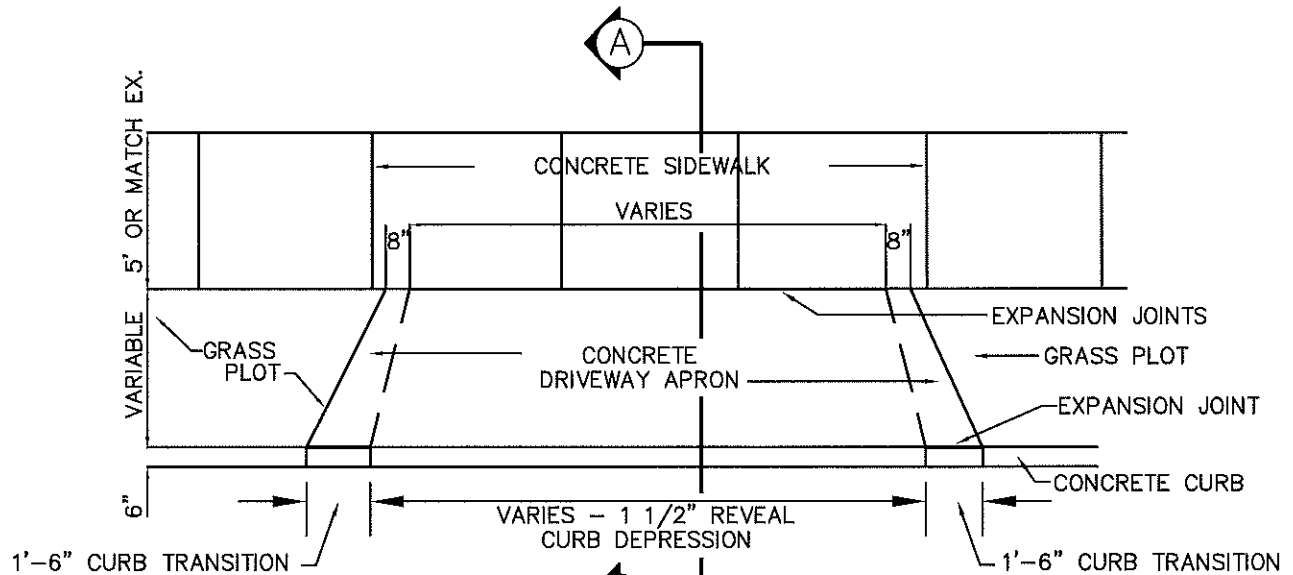

PLAN VIEW

N.T.S.

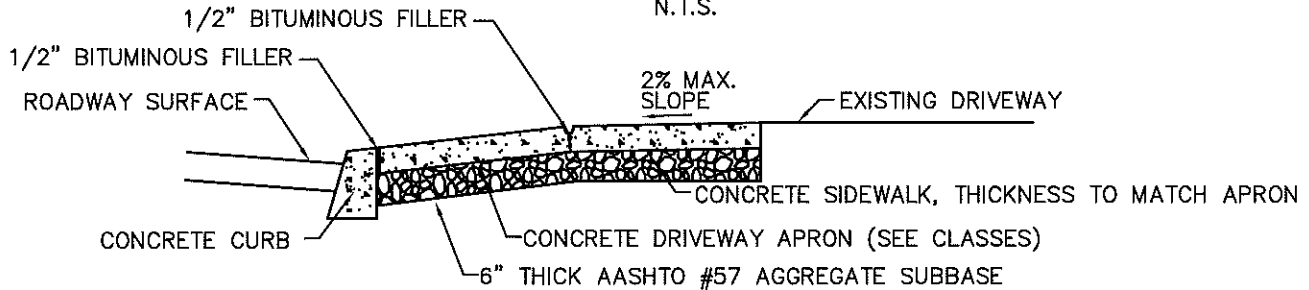

SECTION "A-A"

N.T.S.

DRIVEWAY APRON & CURB DEPRESSION

(APPLICABLE WITH STANDARD CURB)

N.T.S.

NOTES:

1. ALL CONCRETE IS TO BE 3,500 P.S.I., CLASS AA.
2. DEPRESSED CURB SHALL BE SLOPED 1/4" PER FOOT TOWARDS THE STREET.
3. CONCRETE SHALL BE ALLOWED TO CURE FOR SEVEN (7) DAYS.
4. USE OF "HIGH EARLY" CONCRETE MAY BE APPROVED BY THE BOROUGH INSPECTOR.
5. MONOLITHIC POURS SHALL ONLY BE PERMITTED BY SPECIAL EXCEPTION, AND ARE SUBJECT TO APPROVAL BY THE BOROUGH.
6. CONTRACTOR SHALL PROVIDE EROSION CONTROLS TO CONTAIN OPEN EXCAVATIONS AND PROTECT THE NEAREST DOWNSTREAM INLET.

DRIVEWAY APRON CLASSES - MINIMUM STANDARDS:

1. RESIDENTIAL - 6" THICKNESS WITH 6X6-W1.4/W1.4 WIREMESH REINFORCEMENT
2. COMMERCIAL - 8" THICKNESS WITH 6X6-W2.1/W2.1 WIREMESH REINFORCEMENT
3. INDUSTRIAL - DESIGN TO BE PROVIDED TO BOROUGH ENGINEER.

*DETERMINATION OF CLASS SUBJECT TO APPROVAL BY THE BOROUGH.

DETAIL - G
CONSTRUCTION DETAILS
BOROUGH OF PHOENIXVILLE
CHESTER COUNTY, PENNSYLVANIA