

BENCH DONATIONS FOR PARKS & TRAILS

The Borough of Phoenixville accepts bench donations on a case-by case basis. The Borough Manager decides if they have locations that are available and appropriate, for public use.

BENCHES & PLAQUES

Benches are ONLY ordered two times each year-September and March. It normally takes 4-6 weeks from when a bench is ordered until it is actually installed.

All benches are 6' in length, cedar-colored and made from recycled lumber. All plaques are bronze metal and are approximately 10" long x 3 ½" high. Donors provide appropriate wording for plaques and then will be sent a proof for review and approval. The Borough of Phoenixville is not responsible to replace any plaques that may be damaged or stolen. No flowers, shrubs or other decorations are permitted with the bench, without prior approval from the Borough Manager.

COST

The cost for the bench donation package is \$900.00. This price includes:

- 6' Bench
- Bronze Plaque
- Labor to assemble bench, mount plaque and install bench on location

FULL PAYMENT IS REQUIRED BEFORE ANY BENCHES OR PLAQUES ARE ORDERED

Specifications

Steel Slat Arched Back Park Bench

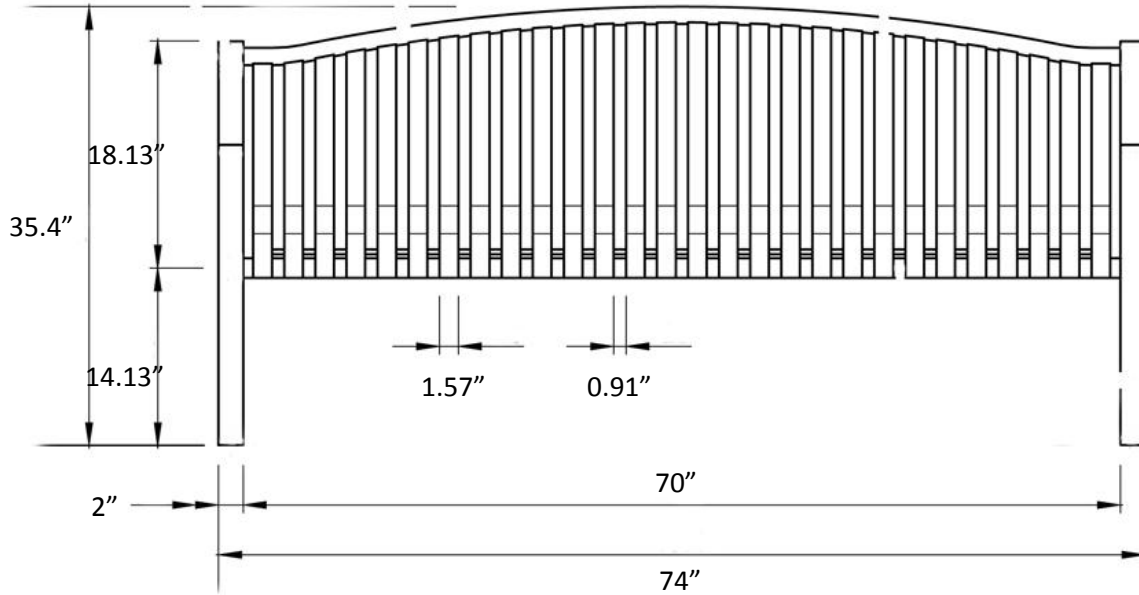

Front View

Length
74"

Width
25.4"

Height
35"

Seat height
18"

Steel slats
Width: 1.57"
Thickness: 0.177"
Space in between: 0.91"

Material: Cold rolled carbon steel
Finish: Powder coating
Fasteners: Stainless steel

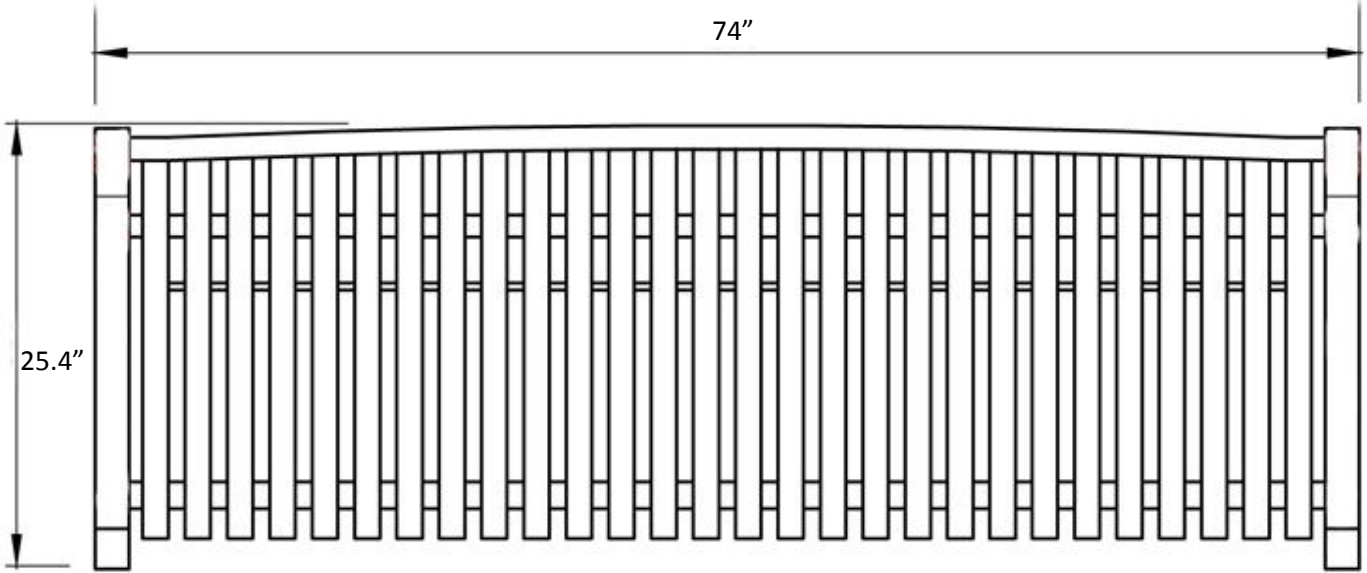

Top View

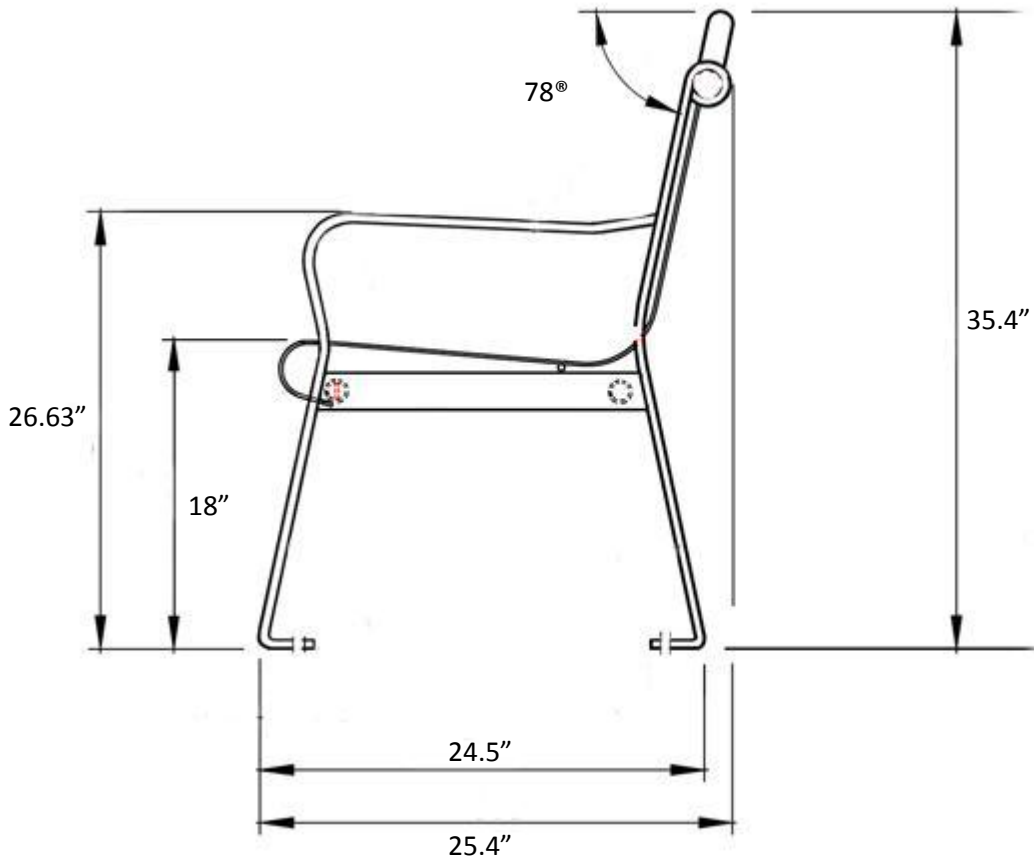

End View





The Borough of Phoenixville

351 Bridge Street - 2nd Floor Phoenixville, PA 19460

Phone: (610) 933-8801 www.phoenixville.org

Memorial Bench Order Form

Date: _____ Name: _____

Mailing Address: _____

Daytime Phone: _____ Alternate Phone: _____

Email Address: _____

Bench Information:

Benches are ONLY ordered two times a year March and September. It normally takes 4-6 weeks from when a bench is ordered until it is actually installed. All benches are 6' in length, cedar-colored and made from recycled lumber. No flowers, shrubs or other decorations are permitted with the bench, without prior approval from the Borough Manager.

Location preference: _____

(Specific park and area)

The Borough reserves the right to change location based on surrounding conditions.

Plaque Information:

All plaques are bronze metal and are approximately 10" long x 3 1/2" high and can contain up to 4 lines. Donors provide appropriate wording for plaques and then will be sent a proof for review and approval. Borough of Phoenixville is not responsible to replace any plaques that may be damaged or stolen. Please indicate below the wording you would like on the plaque.

Cost: \$900.00(Subject to Change) Checks should be made payable to **The Borough of Phoenixville.**

This price includes:

- 6' Bench
- Bronze Plaque
- Labor to assemble bench, mount plaque and install bench at final location as approved by The Borough of Phoenixville.

Mail this form and check to:
Borough of Phoenixville
Attn: Memorial Bench Program
351 Bridge Street, 2nd Floor
Phoenixville, Pa 19460

FULL PAYMENT IS REQUIRED BEFORE ANY BENCHES OR PLAQUES ARE ORDERED